

HÖRMANN

Spindle drive operator for hinged gates

DSA 100
DSA 100 L
DSA 200
DSA 200L

Installation Instructions



1 Overview of spindle drive operator for hinged gates

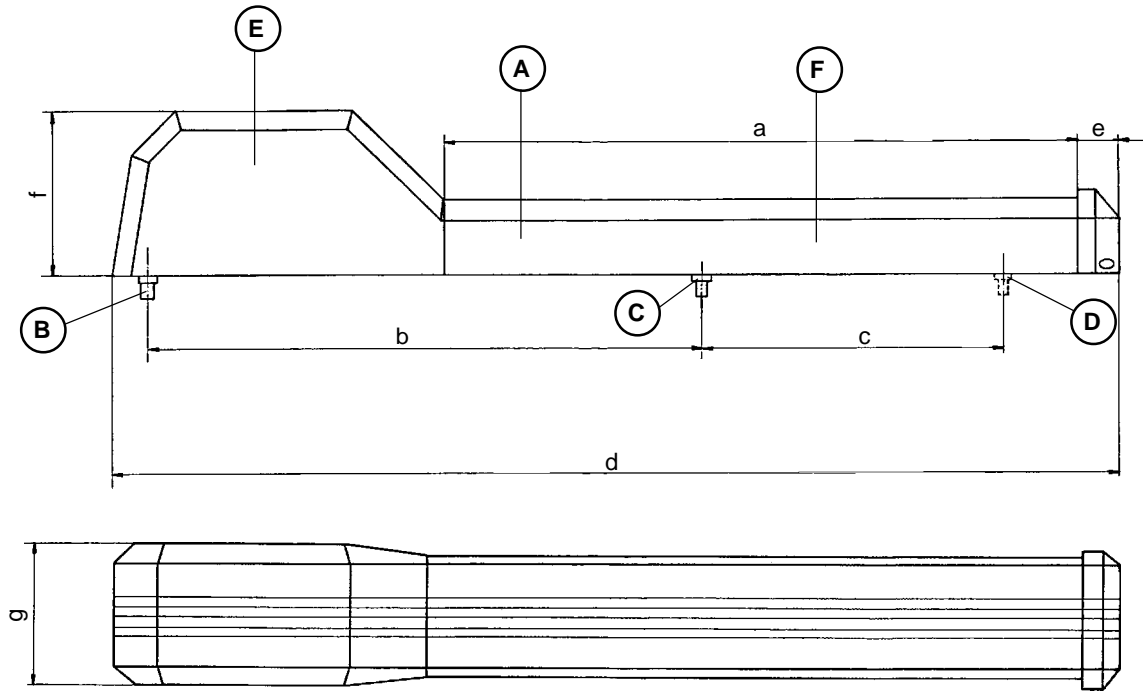
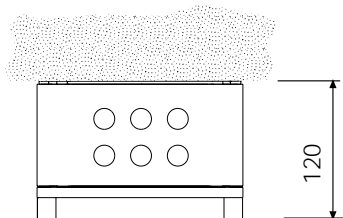
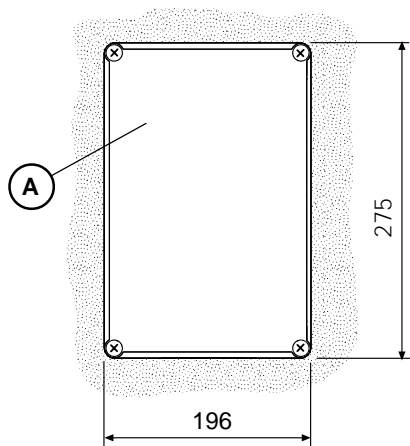

Table 1: Drive operator dimensions

	a	b	c	d	e	f	g
"Standard" version	535	465	300	816	27	140	120
"Long" version	735	565	400	1016	27	140	120

- A Spindle drive operator
- B Pivot - post
- C Pivot - gate wing, "open" position
- D Pivot - gate wing, "closed" position
- E Motor with position sensor (speed registration)
- F Reference point

2 Overview of spindle drive operator for hinged gates



A Electronic control unit

Voltage:	220 - 240 V, 50 Hz
Current input:	1 A max.
Power input:	0.24 kW max.
Temperature tolerance:	-30°C to +70°C
Operation:	4 min. short-term action
Motor:	Spindle unit with 36 V D.C. worm gear motor
Control voltage:	Low tension under 24 V
Motor unit pulling and thrust power:	1000 N
Motor unit travel speed:	10.5 mm/sec
Opening time for 90°:	20 - 30 sec. depending on gate size
Travel time limit:	50 sec.
Automatic cut-out:	Programmable electronic power limit, separately adjustable for both operational directions.
Final cut-off:	Electronic, through microprocessor, with incremental hodometry (path measuring system)
Unlocking device:	With norm cylinder and unlocking mechanism in gate wing mounting bracket
Total weight (single-wing version):	12 kg
Total weight (double-wing version):	18 kg
Safety type motor:	IP 44
Safety type control unit:	IP 65

3 Hörmann aluminium hinged gate system

3a Overview of single-wing version

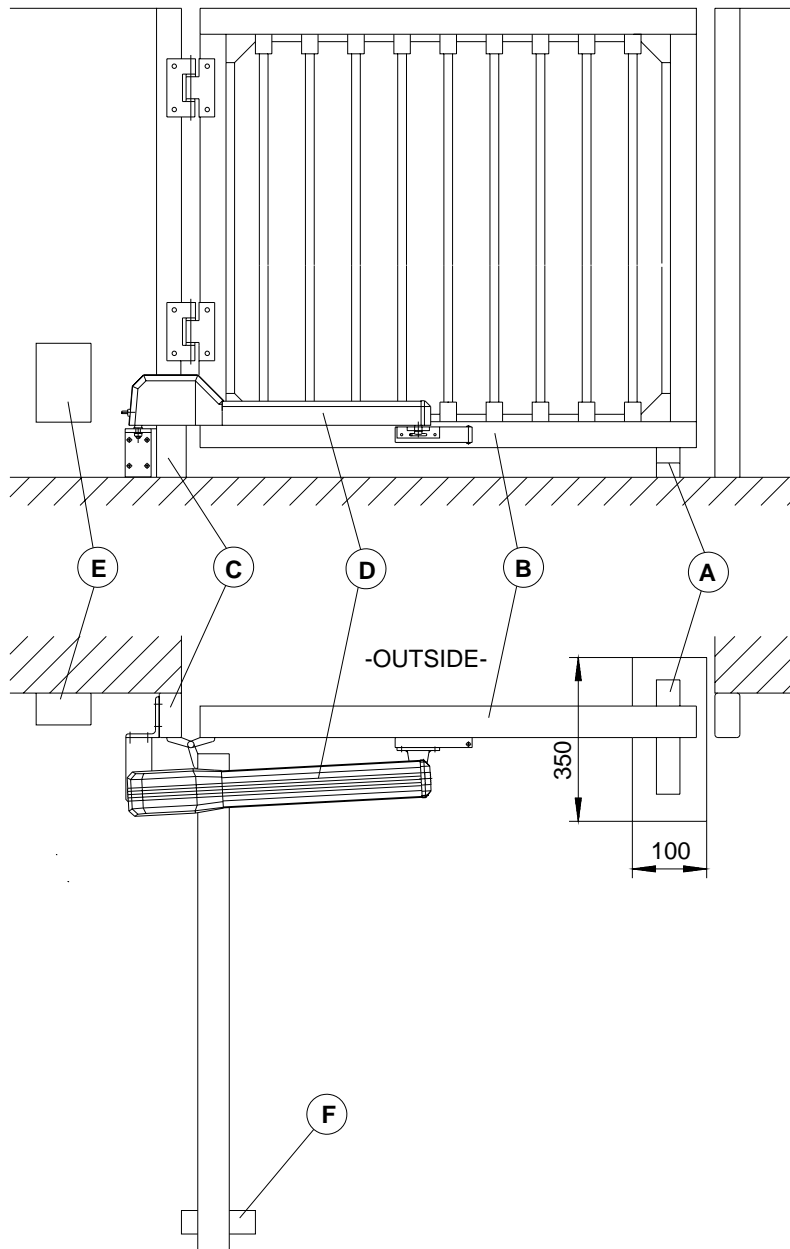

- A Stop plate with lock
- B Gate wing
- C Gate post
- D Spindle drive operator
- E Control unit
- F Gate contact "open" (on site)

3b Overview of double-wing version

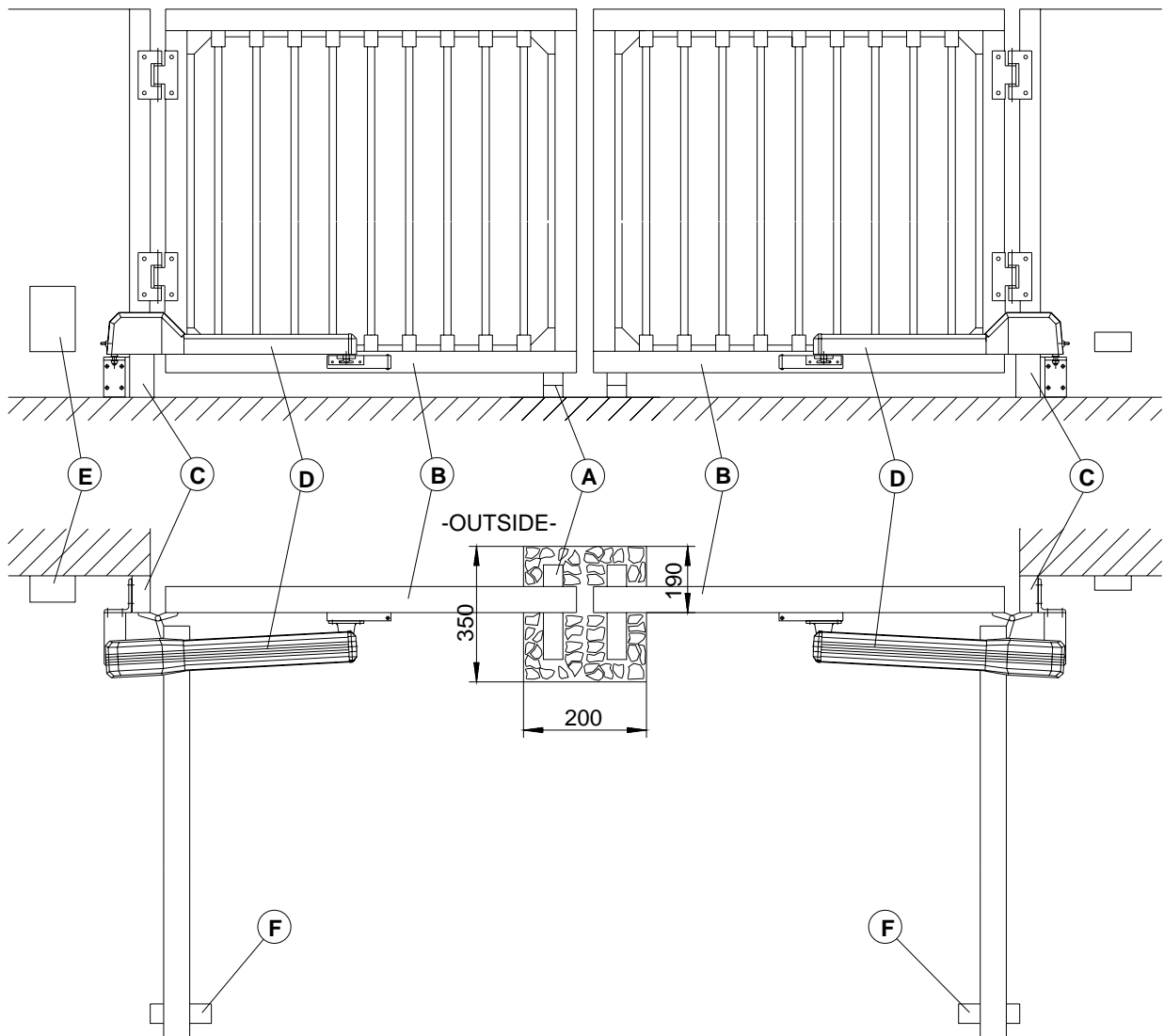

- A Stop plates with lock
- B Gate wing
- C Gate post
- D Spindle drive operator
- E Control unit
- F Gate contact "open" (on site)

3c Overview of post construction, rectangular profile 120 x 60

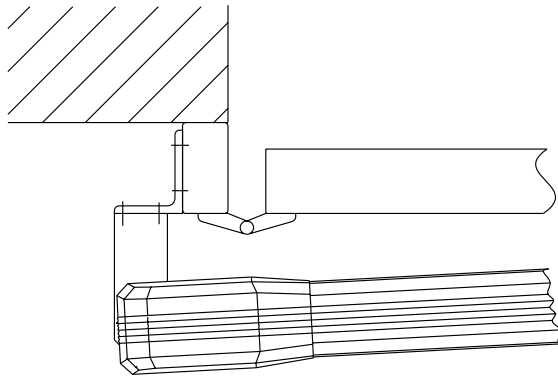

3d Overview of post construction, rectangular profile 120 x 200

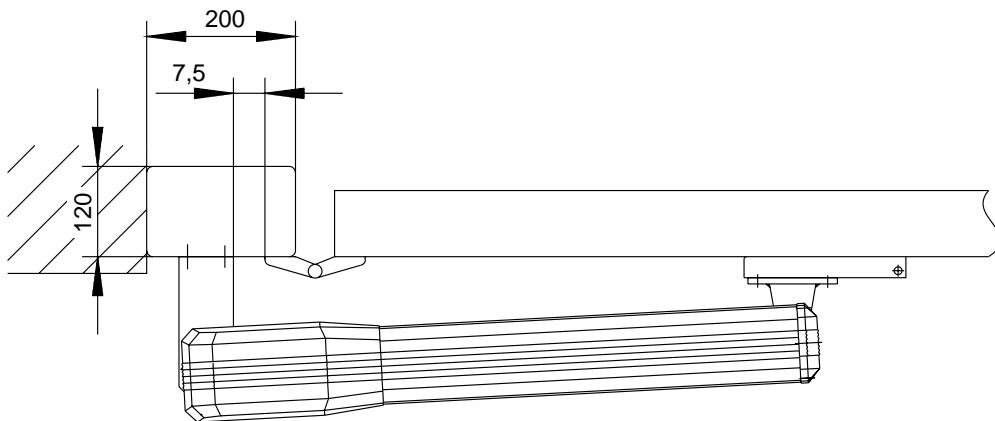

3e Overview of post construction, rectangular profile 120x60 or 120x120

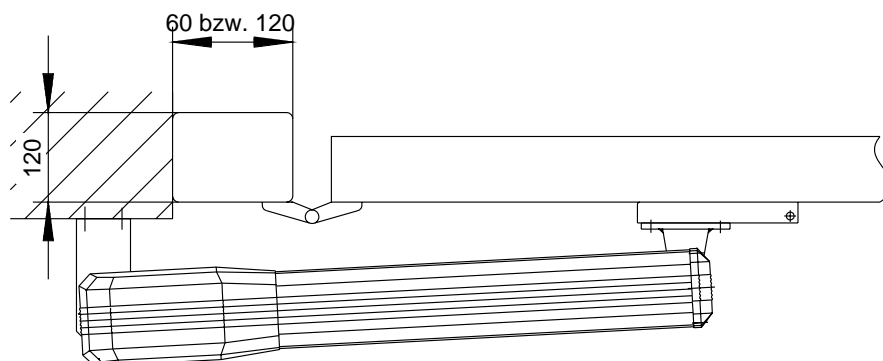

3f Fitting the mounting bracket

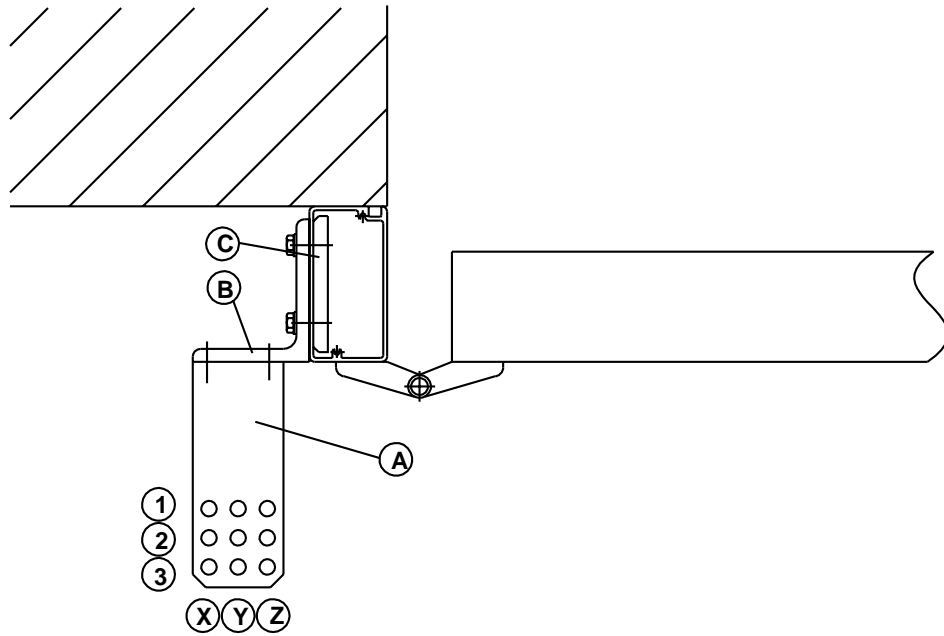

As shown in fig. 3f, screw post mounting bracket (A) and angle piece (B) together with the counterplate (C), pre-fitted in the post. When installing the post in the driveway (figs. 3d and 3e), remove the angle plate and secure the mounting bracket according to the dimensions stated in table 2.

- A Post mounting bracket
- B Angle plate
- C Counterplate

3g Determining the pivot points

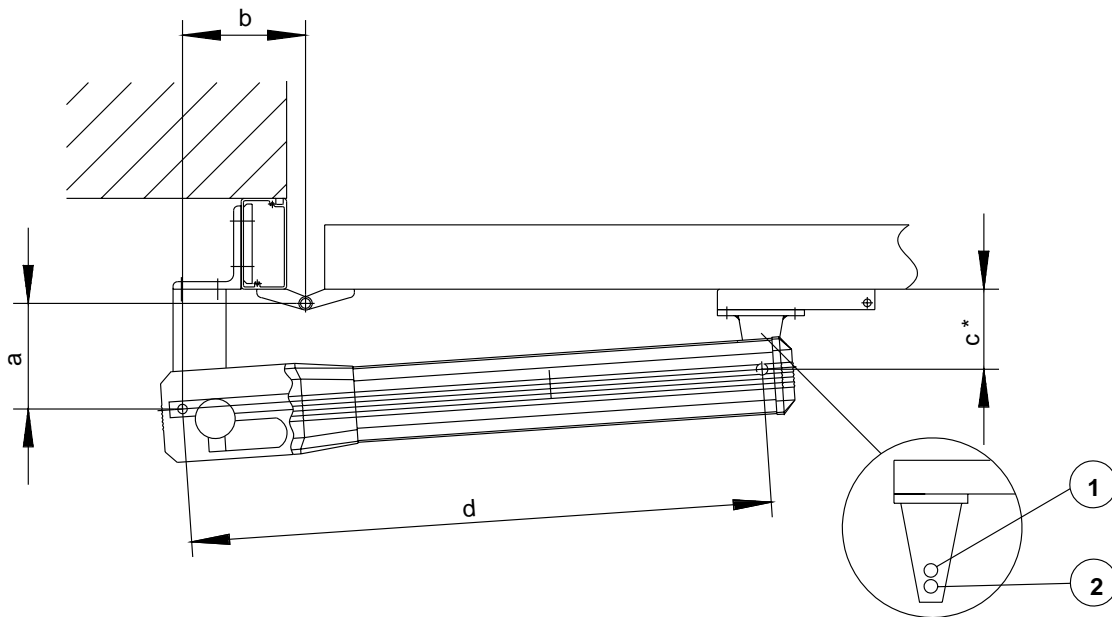

The distances between the gate pivot point and the drive operator pivot point are determined by the spindle stroke of 300 mm, which can be used fully or only partially to achieve a wing opening angle of 90°.

With an opening angle of 90°, the following reference values apply:

Spindle lift = $a + b$, whereby a and b should be chosen more or less equal.

In the case of larger gate wings, the full working stroke should be used in order to limit the gate speed of the wing outer edges. For smaller gate wings, the opening time can be reduced by decreasing the values a and b .

For Hörmann aluminium hinged gate systems the values listed in table 2 are applicable for the dimensions in fig. 3g. To make it easier to determine the fixing point, the X, Y, Z hole size co-ordinates, separate for left- and right-hand hinging, can be taken from fig. 3f. It is important to observe the specified dimensions. Insert the hinged gate drive operator into the corresponding drill hole of the post mounting bracket and screw in place with hexagon nut M 10. If the spindle is retracted, connect the front hinge of the drive operator, fig. 1, point C, to the mounting bracket on the gate wing, and with the gate in the "open" position, fix this to the gate wing.

Table 2

Wing width mm	a mm	b mm	LH- hinging	RH- hinging	c	dmax. mm	Opening time in sec. at 90°
1000 - 2000	88	107	Z1	X1	*	765	19
2000 - 2500	108	107	Z2	X2	*	765	21
2500 - 3000	108	127	Y2	Y2	*	765	23

* Distance "c" with LH-hinging (drive operator on left gate wing, as illustrated): hole 1

* Distance "c" with RH-hinging (drive operator on right gate wing): hole 2

4 General hinged gate systems, retrofitting of Electr. drive operator

4a Overview of single-gate version

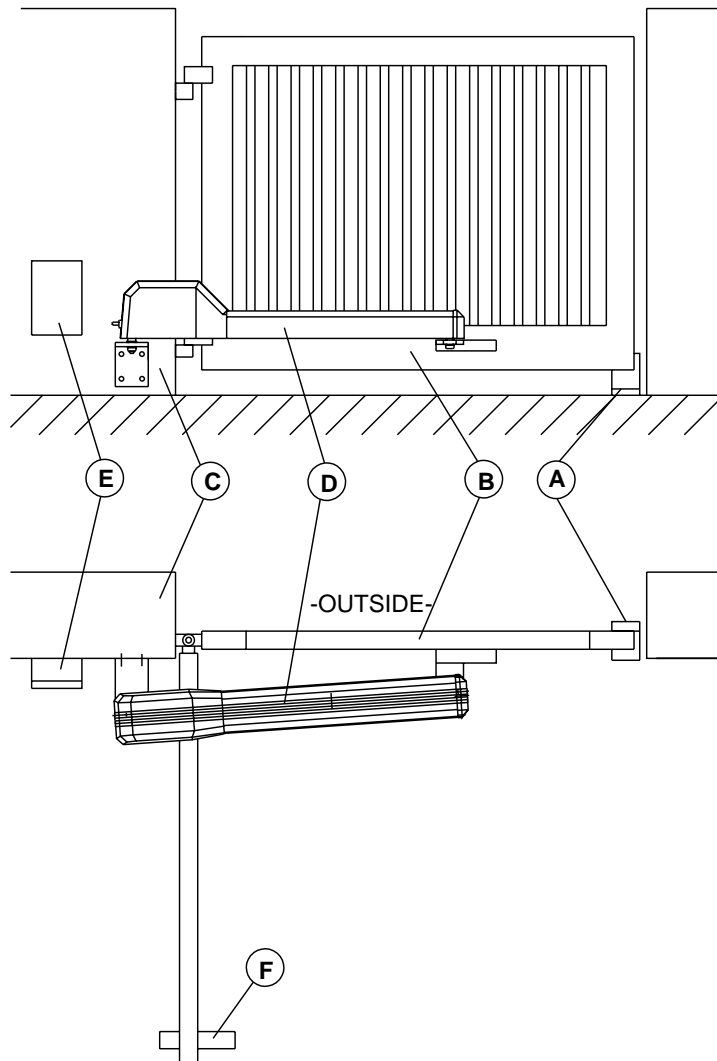

- A Stop plate "close" (on site)
- B Gate wing
- C Post
- D Spindle drive operator
- E Control unit
- F Gate contact "open" (on site)

4b Overview of two-wing version

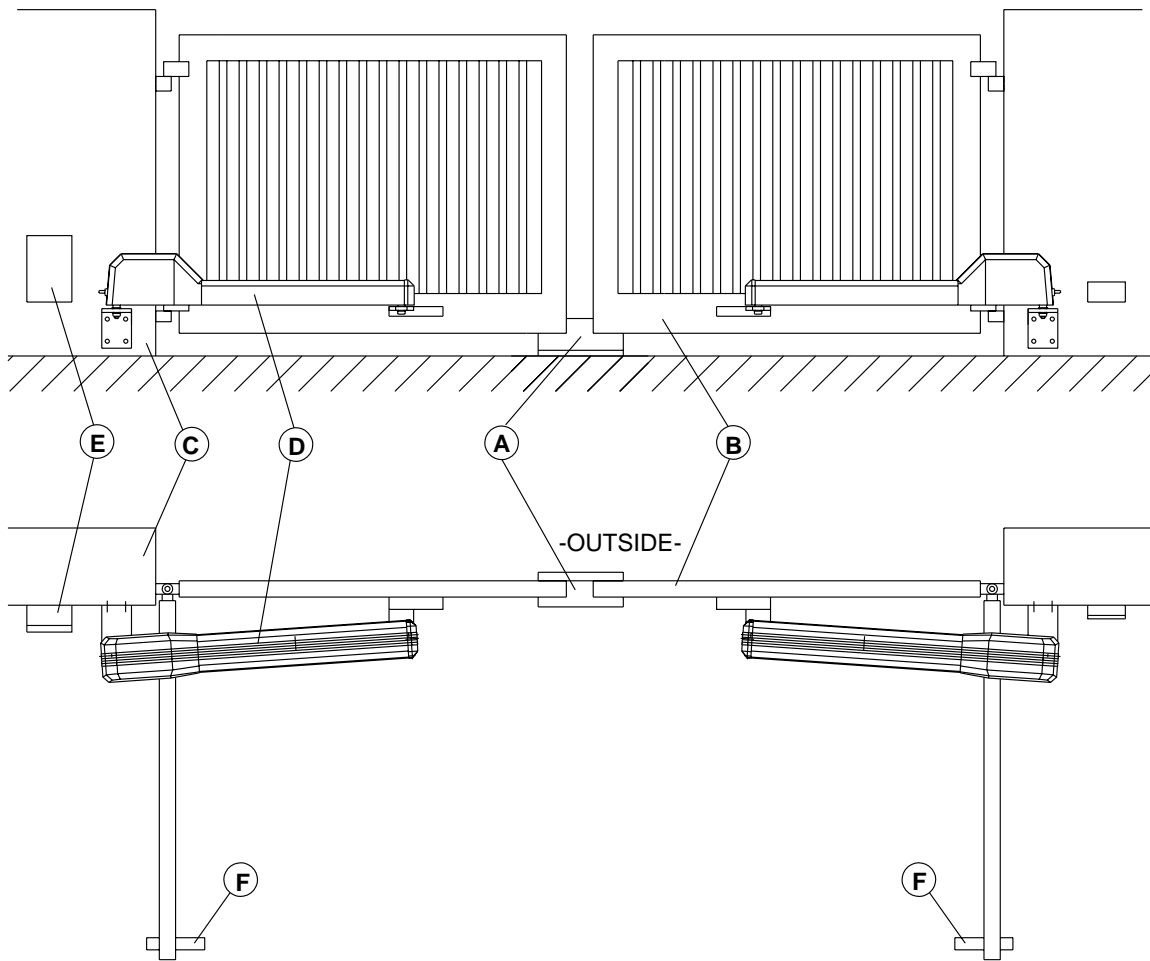

- A Stop plate "close" (on site)
- B Gate wing
- C Post
- D Spindle drive operator
- E Control unit
- F Gate contact "open" (on site)

4c Fixing the pivot points

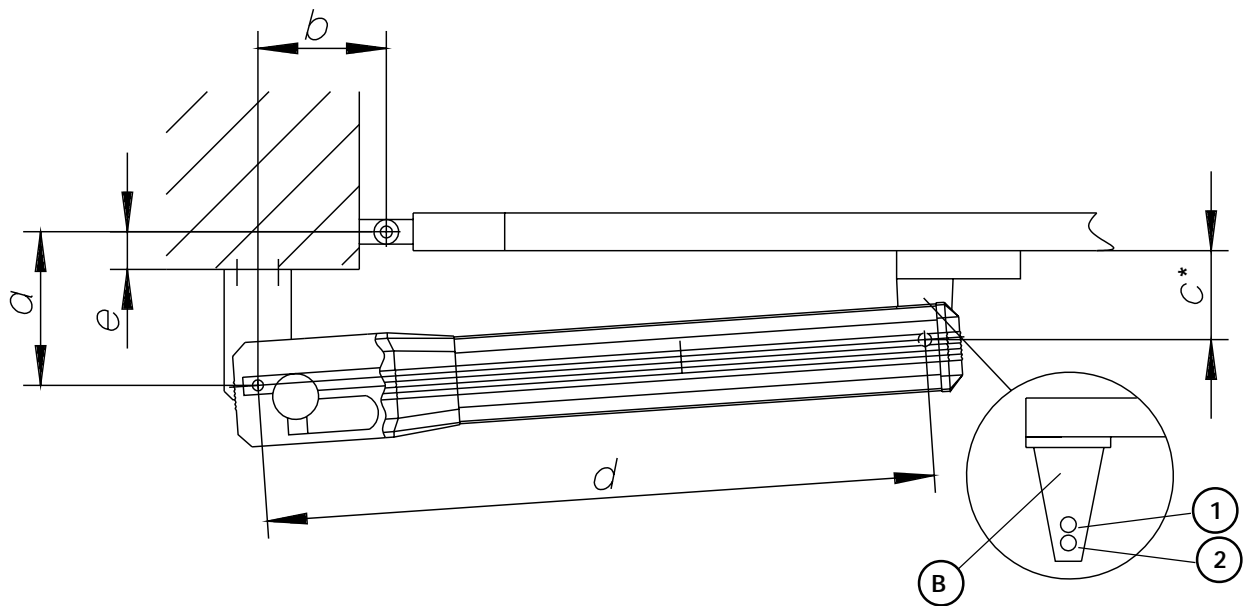

- * Distance „c” for LH hinging (drive operator on left gate wing): drill hole 1
- * Distance „c” for RH hinging (drive operator on right gate wing): drill hole 2

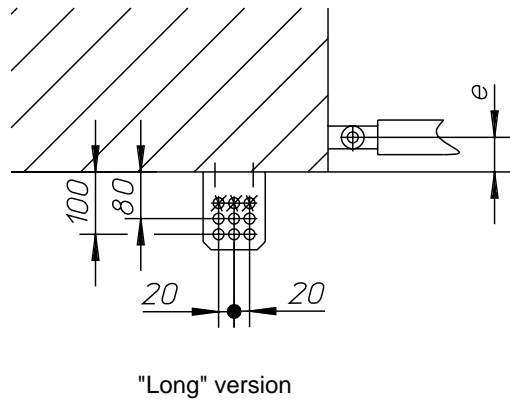
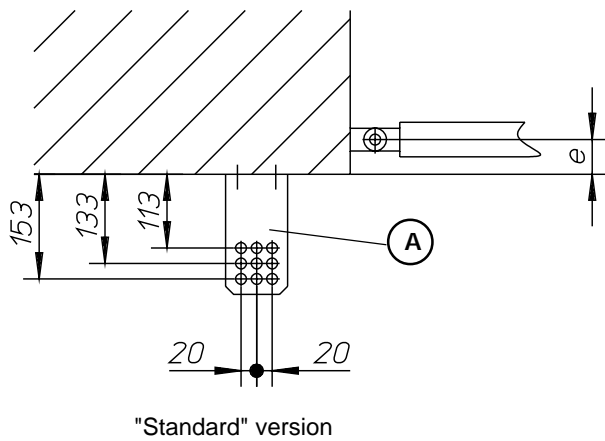

e = On-site building-in depth

- A Post mounting bracket
- B Release box on the gate wing

4d Installing the fittings

Post mounting bracket

In order to ensure an opening angle of 90 degrees, the addition of measurements a + b should roughly correspond to the spindle stroke.

a + b = 225 ... 285 mm for the „standard“ version

a + b = 240 ... 380 mm for the „long“ version

For larger gate wings, the full working stroke should be used in order to limit the gate speed of the wing outer edges.

Anchor the post mounting bracket in the masonry (see fig. 3c).

Building-in dimensions are specified in tables 2 + 3.

If the on-site maximum building-in measurement „e max“ exceeds the specified values, then the drive operator must be set into the masonry with the mounting bracket.

Insert the hinged gate drive operator into the corresponding drill hole of the post mounting bracket and screw tight with an M10 hexagon nut.

Table 2: If the building-in dim. is less than 40 mm, use the „standard“ version of the spindle drive operator

Building-in dim. e mm	Preferred dimensions for gate wing width <2000				Preferred dimensions for gate wing width >2000			Preferred dimensions for largest possible opening angle		
	a mm	b mm	Opening angle degrees	Opening time sec.	b max. mm	Opening angle degrees	Opening time sec.	b min. mm	Max. opening angle degrees	Opening time sec.
less than 0	125	100	90°	16	160	90°	21	140	110°	22
0 - 20	135	100	90°	18,5	140	90°	21	120	105°	22
20 - 40	155	100	90°	20	115	90°	21	115	100°	22

Table 3: Building-in dim. e = 40 ... 200 mm. Use the „long“ version of the spindle drive operator

Building-in dim. e mm	Preferred dimensions for gate wing width <2000				Preferred dimensions for gate wing width >2000			Preferred dimensions for largest possible opening angle		
	a mm	b mm	Opening angle degrees	Opening time sec.	b max. mm	Opening angle degrees	Opening time sec.	b min. mm	Max. opening angle degrees	Opening time sec.
40 - 60	140	100	90°	18,5	240	90°	28	180	120°	29
60 - 80	160	100	90°	19,5	220	90°	28	180	115°	29
80 - 100	180	100	90°	21,5	200	90°	28	160	110°	29
100 - 120	200	100	90°	22	180	90°	29	160	100°	29
120 - 140	220	100	90°	24	160	90°	29	140	100°	29
140 - 160	240	100	90°	26	140	90°	29	120	100°	29
160 - 180	260	100	90°	28	120	90°	29	100	95°	29
180 - 200	280	100	90°	29	100	90°	29	100	90°	29

Release box (for single-wing version, this may have to be reversed, depending on which side the gate is hinged)

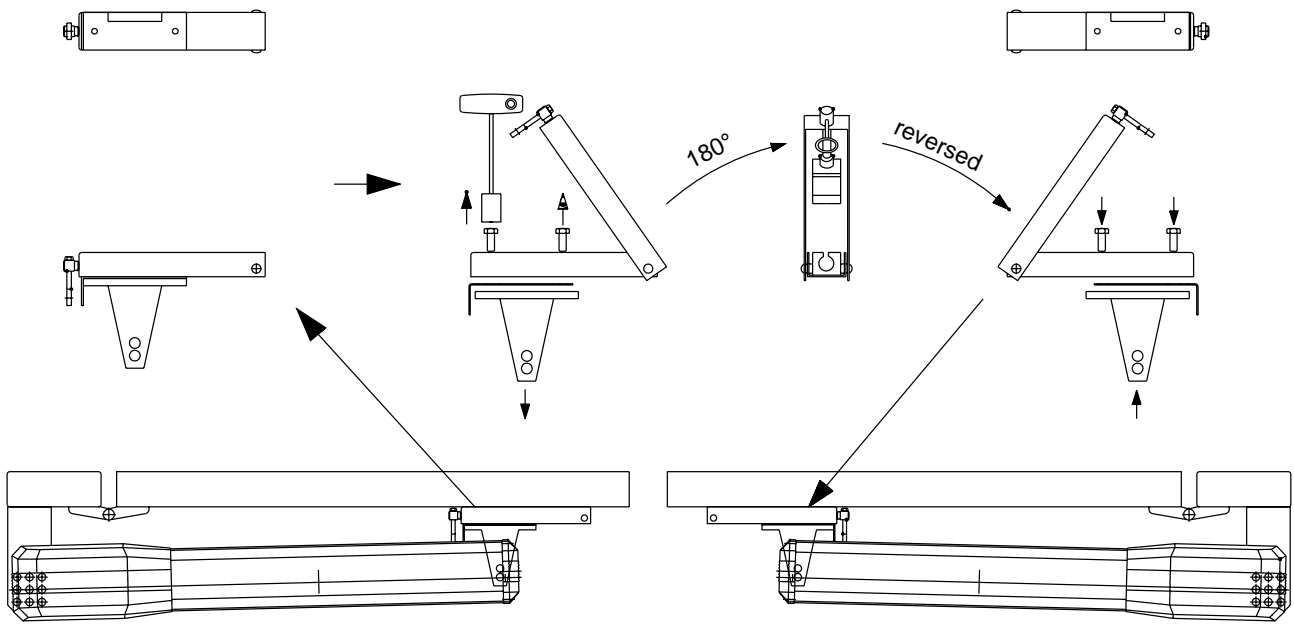

Fitting the release box to the gate wing

To establish the fixing points on the gate wing:

With the spindle fully extended, connect the hinged gate operator in alignment with the release box and mark the position. Open the release box and drill 2 holes centrally within the elongated holes (6 mm dia. drill). Make the release box and the drive operator secure, then make a test run. Carry out any necessary fine adjustment via the elongated holes. Remove rotary latch. Drill the outer hole and then screw the centrally located screw into this drill hole. This will prevent the box from sliding sideways. Push rotary latch back in again. Place on washer and tighten hexagon nut until rotary latch is sluggish to operate.

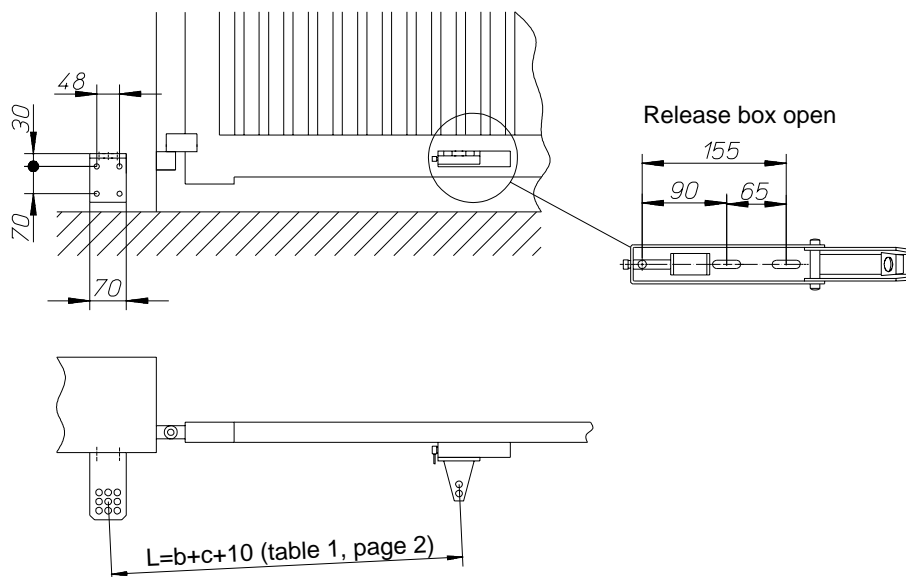

5 Overview of cable layout

5a Single-wing gate system

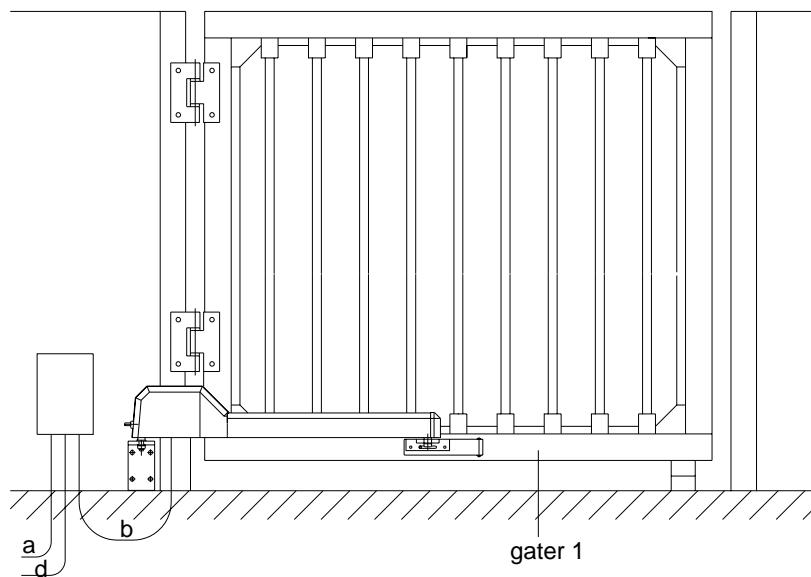

5b Two-wing gate system

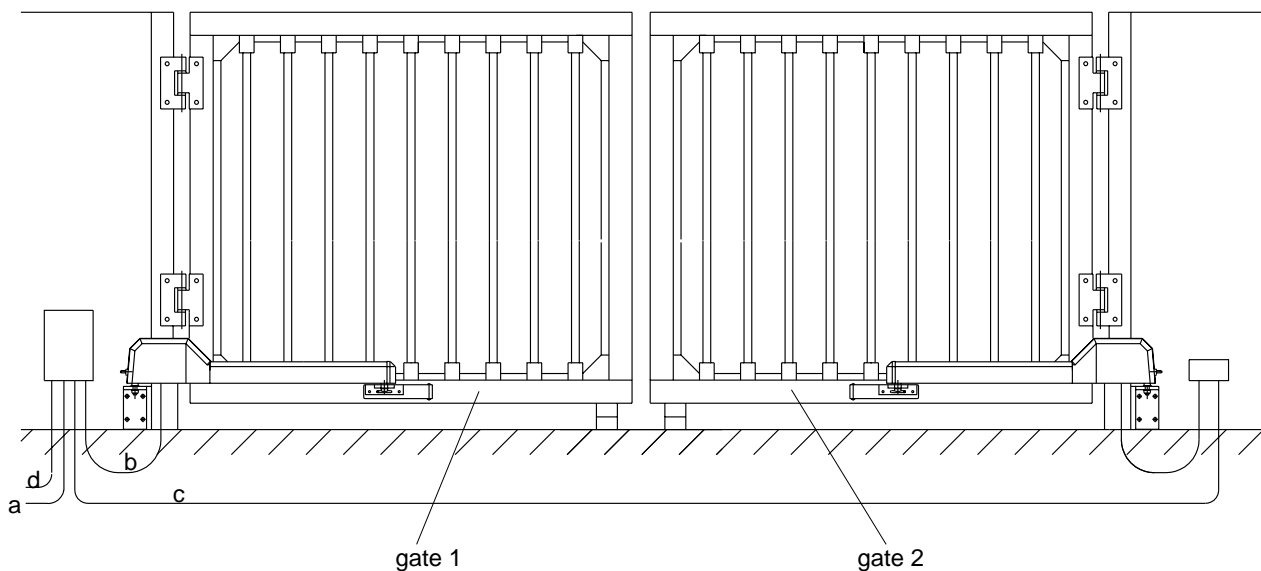

Secure the control unit to the post using wall plugs and screws, then plug into mains and make a test run. On completing the test run, remove mains lead with plug and have the control unit properly connected to the electricity supply by a qualified electrician.

- a Mains lead 240 V 50 Hz (e.g. NYY 3 x 1.5 by customer)
- b Connecting cable for motor (by Hörmann)
- c Connecting cable for motor (by Hörmann or NYY - 0 9 x 1.5 with junction box - by customer)
- d Control cable for pressure switch, key switch (e.g. NYY - 0 56 x 1.5 by customer).

* If the control unit cannot be installed near the gate, please request a corresponding cable layout plan.

6

Overview of control unit D 200; single- and two-wing versions

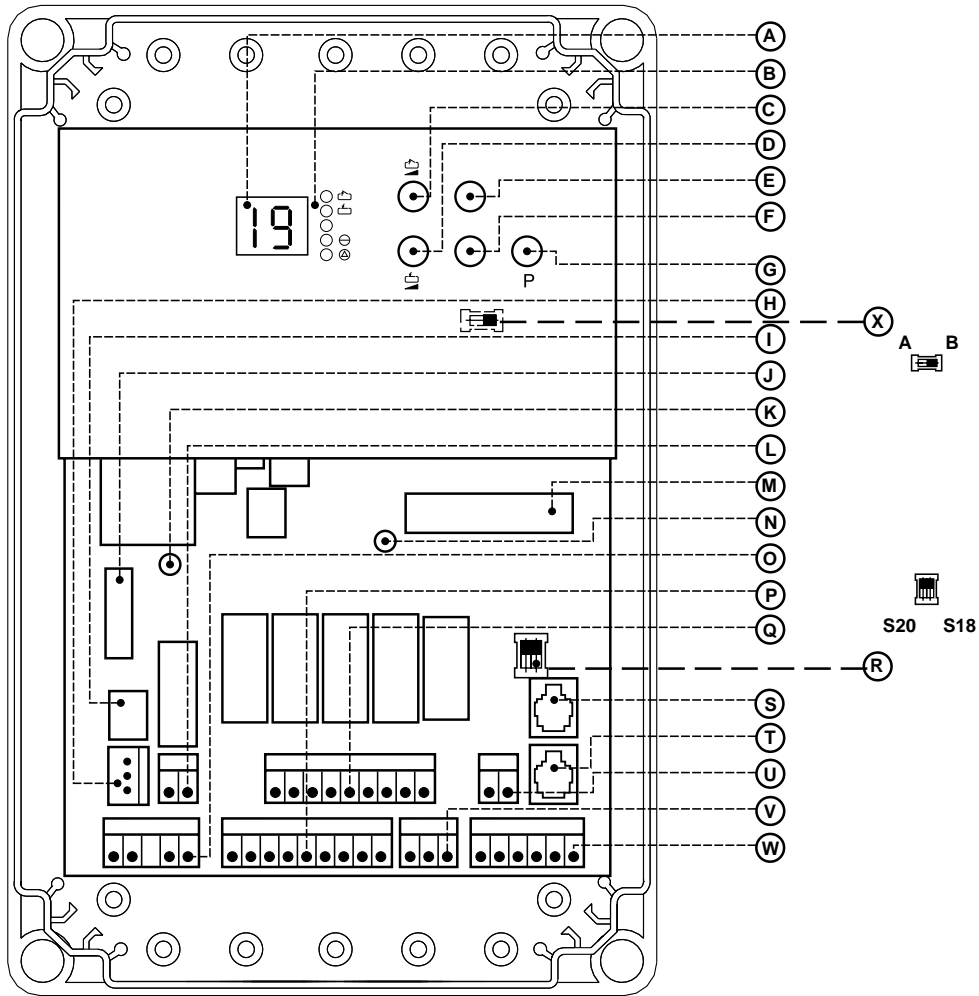

- A Indicator
- B LED
- C Power limit "open"
- D Power limit "close"
- E Test button "open"
- F Test button "close"
- G Coding button
- H Plug-in connection transformer 220 V
- I Mains fuse F1, 1A max.
- J Motor fuse F2 4A max.
- K LED motor voltage
- L Socket for on-site lighting
- M Plug-in connection control panel
- N LED socket
- O Plug-in terminal X2a mains voltage
- P Plug-in terminal X2e motor connection gate wing 1
- Q Plug-in terminal X2d motor connection gate wing 2
- R Switch S 18, S 20
- S System socket for electronic aerial
- T System socket X5 open - close - stop
- U Plug-in terminal X2d open - close gate wing 1
- V Plug-in terminal X2f photocell 24 V
- W Plug-in terminal X2e open - close - stop
- X Change-over switch S23: A = single-wing version
B = two-wing version

7 Circuit diagram D 200

7a Single- and two-wing versions

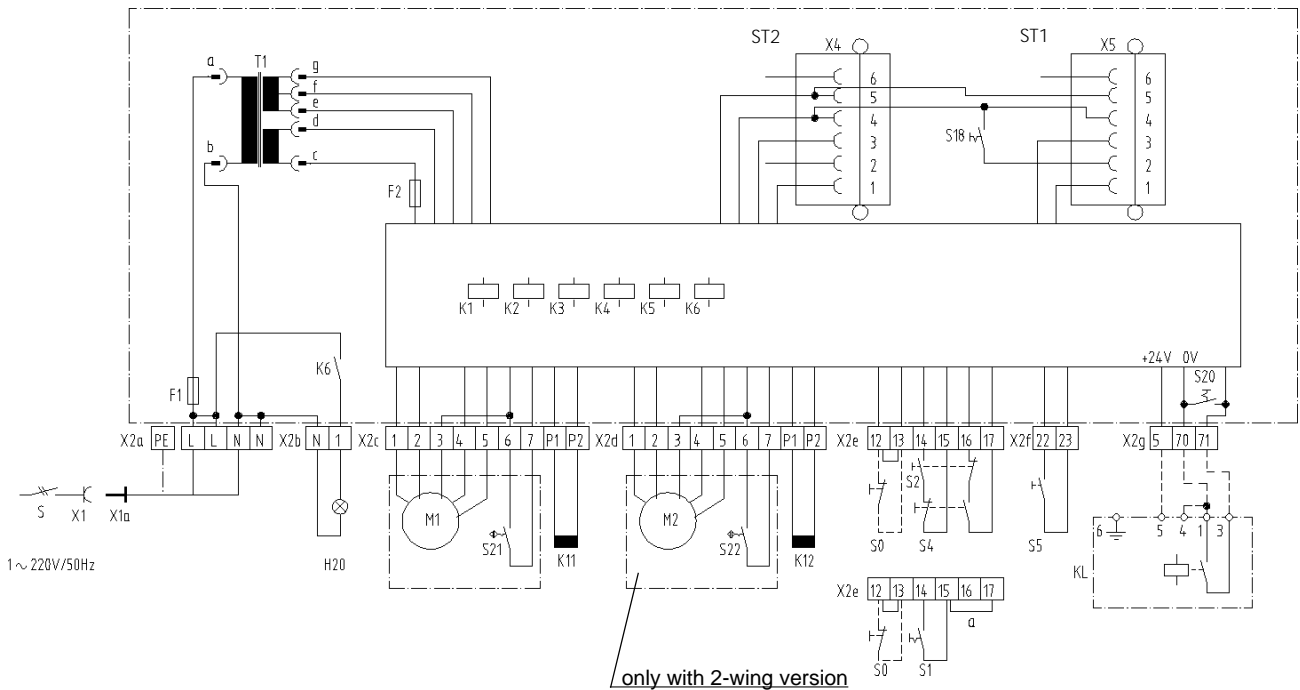

- | | | | |
|-----|---|-----|---|
| F1 | Fuse 1A max | S18 | Coding switch 2nd "stop" button |
| F2 | Fuse 4A max | S20 | Coding switch photocell |
| H4 | LED reference point | S21 | Reed contact reference point (bistable) gate wing 1 |
| H20 | On-site lighting (250V,60W max) | S22 | Reed contact reference point (bistable) gate wing 2 |
| K1 | Relay "open" gate wing 1 | S23 | Change-over switch single- and two-wing version |
| K2 | Relay "close" gate wing 1 | ST1 | Socket for external control elements |
| K3 | Relay "open" gate wing 2 | ST2 | Electronic aerial |
| K4 | Relay "close" gate wing 2 | T1 | Transformer |
| K5 | Relay magnetic lock | X1 | Safety electric socket |
| K6 | Relay light | X1a | Safety plug |
| K11 | Magnetic lock gate wing 1* | X2a | Socket mains connection |
| K12 | Magnetic lock gate wing 2* | X2b | Socket for on-site lighting |
| KL | Photocell | X2c | Socket motor connection gate wing 1 |
| M1 | Motor 36V DC, gate wing 1 | X2d | Socket motor connection gate wing 2 |
| M2 | Motor 36V DC, gate wing 2 (only w.2-wg.vers.) | X2e | Socket connection button open,stop,close |
| S | Main switch or button "Emergency - off"* | X2f | Socket connection "impulse" button gate wing 1 |
| S0 | "stop" button | X2g | Socket connection photocell |
| S1 | "Impulse" button gate wing 1 & gate wing 2* | X4 | Socket "electronic aerial" |
| S2 | "Open" button gate wing 1 & gate wing 2* | X5 | Socket connection button open,stop,close |
| S4 | "Close" button gate wing 1 and gate wing 2* | | |
| S5 | "Impulse" button gate wing 1 | | |
- * if provided

On connecting, remove bridge or turn coding switch to OFF.

Factory-bridged terminals, coding switch			
Description	Terminal block	Bridged terminals	Coding switch
"Stop" button	X2	12 - 13	-
"Stop" button	ST1	-	S18
Photocell	KL	-	S20
"Impulse" button	X2e	a	-

Caution! Low voltage!

External voltage at the terminals will completely destroy the electronics.

Important: Observe local safety regulations!

Always lay mains cable and control cable separately.

Control voltage 24V DC
Motor voltage 40V DC

8 Electronic aerial IP 65

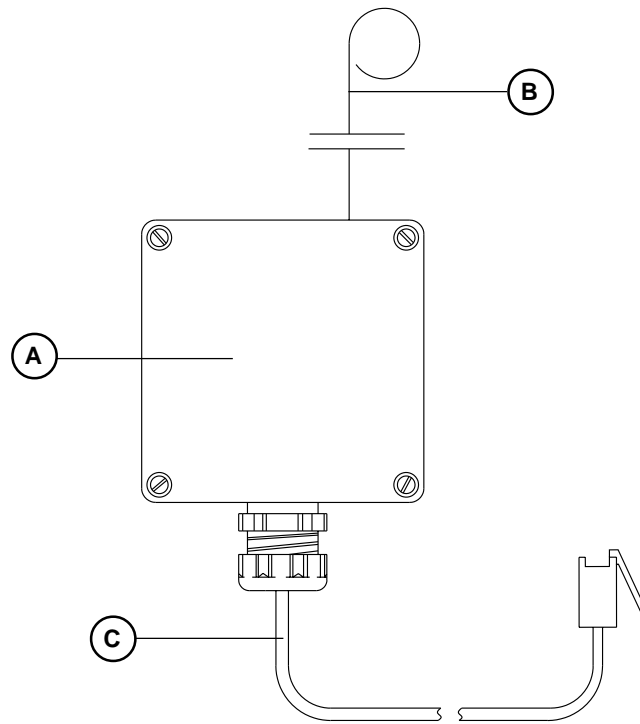



Plug electronic aerial into the control unit (socket ST2) as shown in fig. 6, point "S".
The range may vary with different digital security codings.

- A Electronic aerial box IP 65
- B Aerial
- C Connecting lead with plug

9 Adjustment and coding

9a Putting into operation

Switch on at the mains. LED  lights up. After pressing the test buttons   the gate at first moves in the direction of the reference point.

(If the drive operator is not installed, the swivel joint (fig 1 "C" must be held in a vertical position).

Important: The limit stop is pre-set at the factory.

The power limit can now be set in accordance with fig. 9c.







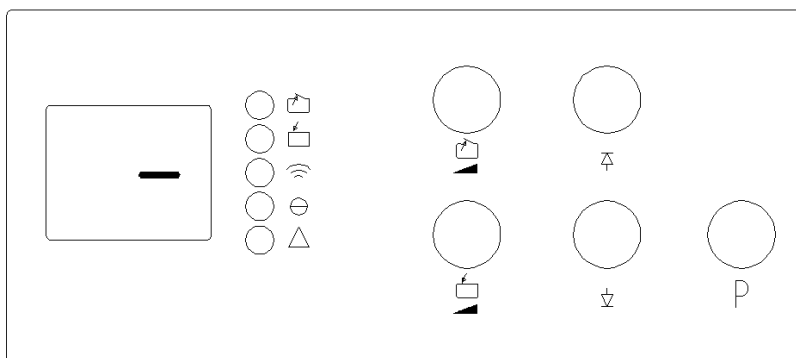

Proceed with programming the remote control as illustrated in fig. 9d.

Press the  button to bring the gate into the final "open" position, then proceed with programming the final positions in accordance with fig. 9e.



The programming procedure terminates automatically 30 seconds after the last entry, or can be terminated manually by pressing the "P" button (see figs. 9d, 9e, 9f, 9g, 9h, 9i and 9n).

9b



- P Coding button
-  Power setting "open"
-  Power setting "close"
-  Test button "open"
-  Test button "close"
-  Final "open" position
-  Final "close" position
-  Remote control
-  Operation/Coding
-  Error message

9c Setting the power limits

Press the  button to set the power limit "open", and press the  button to set the power limit "close". The set value will be indicator.

By repeatedly pressing the appropriate button, the power limit can be set in stages from 0 (most sensitive value) to 19 (pre-set value = 9).

Attention: To protect persons as well as the mechanical parts of the door and operator, set the power limit as sensitively as possible - on no account exceed 150 N (approx. 15 kg.)

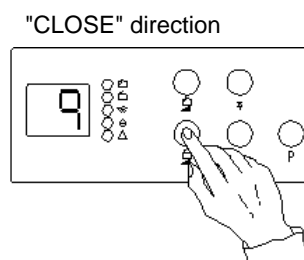
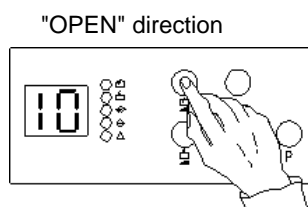

The power limits are now set.

9d

Coding the receiver for single-wing version (only with electronic aerial)

Press button "P" for 2 seconds

"F" is indicator

LED  lights up

LED  flashes

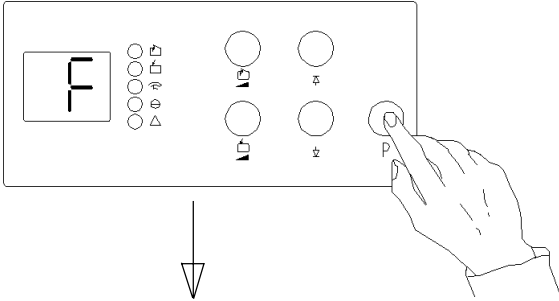

Operate the hand transmitter

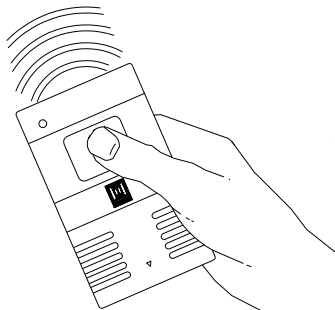

Indicator "-"
Receiver coding is stored

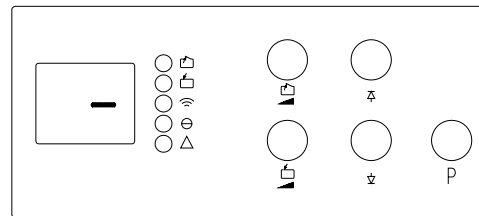

Multi-channel hand transmitter:
Press any button.

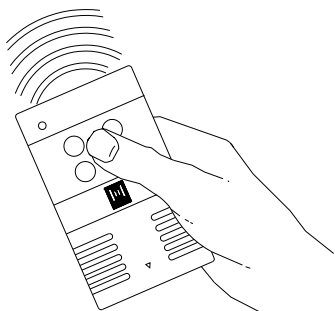

Press button "P"

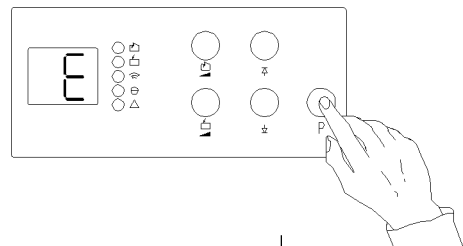

Press button "P" only with autom. timed return

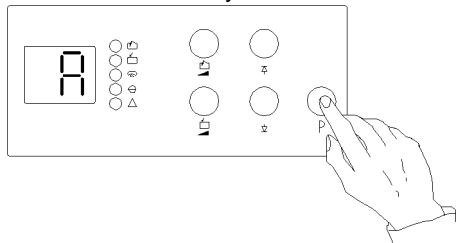

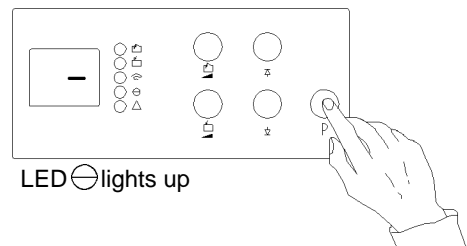

Press button "P"



Programming is completed.

9e

Programming the receiver for two-wing version (only with electronic aerial)

Press button "P" for 2 seconds
"F" is indicator
LED  lights up
LED  flashes

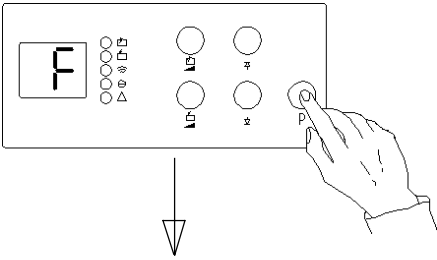

Operate the hand transmitter

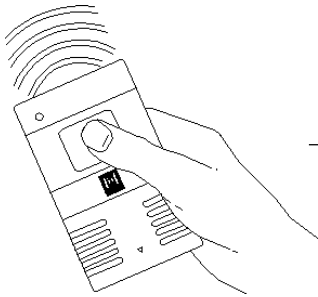

Indicator "-"
Receiver programming is stored

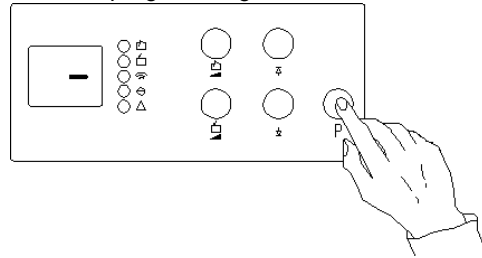

Multi-channel hand transmitter:
Press any button.

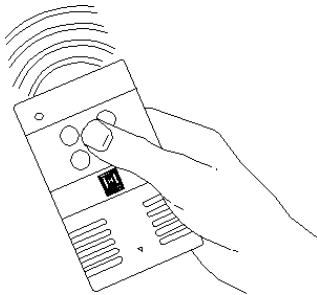

Press button "P"

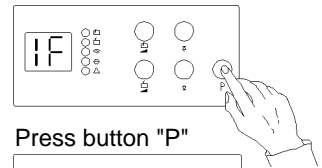

Press button "P"

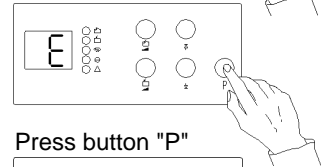

Press button "P"

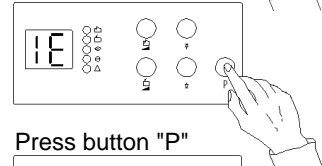

Press button "P"

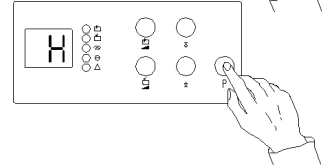

Press button "P" only with
autom. timed return

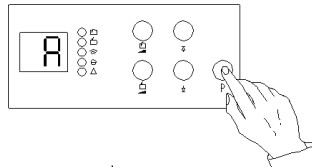

Press button "P"

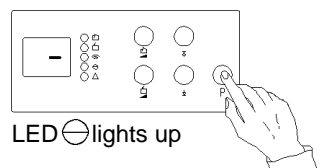

Programming is completed.

9f

Programming the receiver for the two-wing version - gate 1 only

(only with multi-channel hand transmitter, e.g. button "B" with two-wing version and with electronic aerial)

Press button "P" for 2 seconds

"F" is indicator

LED  lights up

LED  flashes

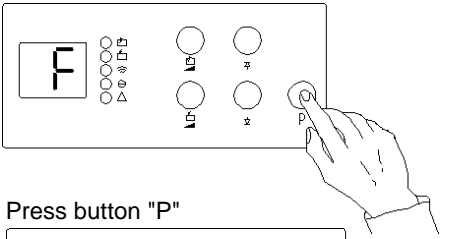

Press button "P"

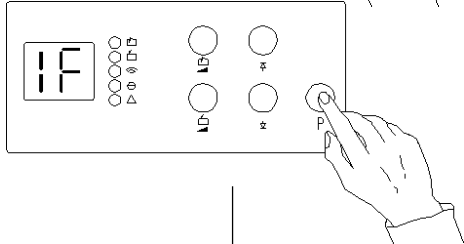

Operate the hand transmitter

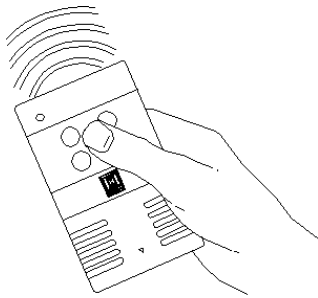

Indicator "-"

Receiver programming is stored

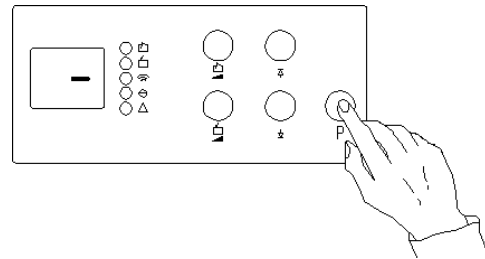

Press button "P"

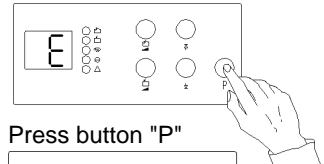

Press button "P"

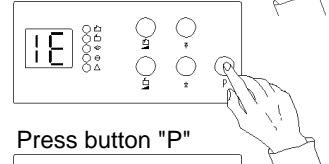

Press button "P"

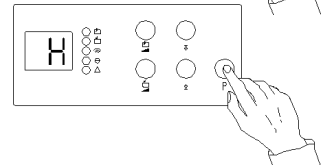

Press button "P" only with
autom. timed return

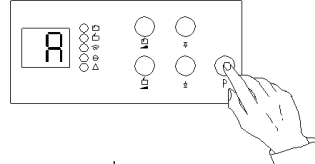

Press button "P"

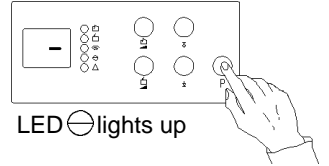

LED  lights up

Programming is completed.

9g

Setting the limit stop for single-wing version (gate must be in "OPEN" position)

Press button "P" for 2 seconds

"F" is indicator

LED  lights up

LED  flashes

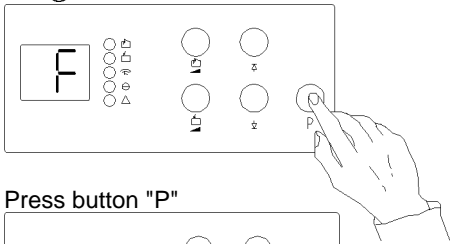

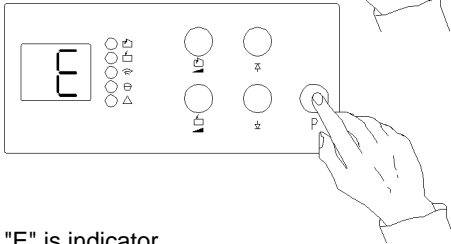

Press button "P"



"E" is indicator

LED  flashes

Press the  button and keep it depressed until the gate has reached the final "close" position.

Fine adjustment can be made by briefly pressing button  or button  which increases or reduces the travel distance of the gate by approx. 4 mm, without the gate moving!

The final "close" position (limit stop) is stored.

Press the  button and keep it depressed until the gate has reached the final "open" position.

Make fine adjustment as described above.

The final "open" position (limit stop) is stored.

"OPEN" direction

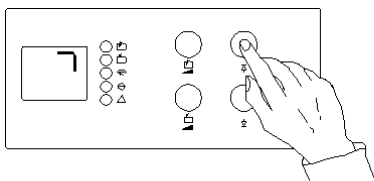

"CLOSE" direction

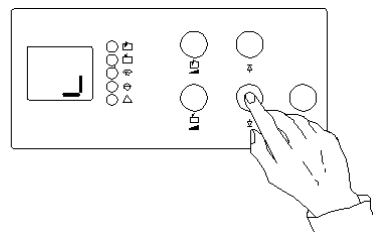

Press button "P" only with
autom. timed return

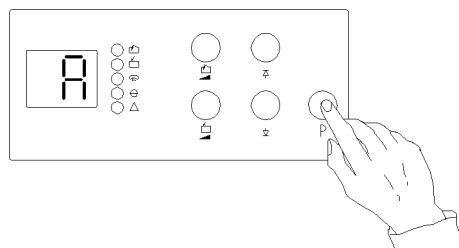

Press button "P"

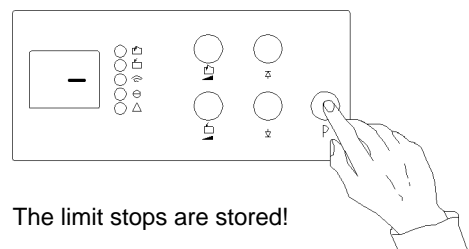

The limit stops are stored!

Programming is completed.

9h

Setting the limit stops for the two-wing version - gate 1 (gate must be in "open" position)

Press button "P" for 2 seconds

"F" is indicator

LED ☹️ lights up

LED ☹️ flashes

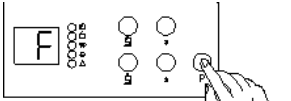

Press button "P"

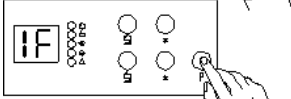

Press button "P"

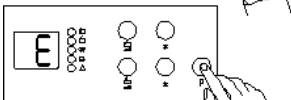

"E" is indicator

LED ☹️ or ☹️ flashes

Press button and keep it depressed until the gate has reached the final "CLOSE" position.

Fine adjustment can be made by briefly pressing button or button which increases or reduces the travel distance of the gate by approx. 4 mm, without the gate moving!

The final "CLOSE" position (limit stop) is stored.

Press button and keep it depressed until the gate has reached the final "OPEN" position.

Carry out fine adjustment as described above.

The final "OPEN" position (limit stop) is stored.

"OPEN" direction

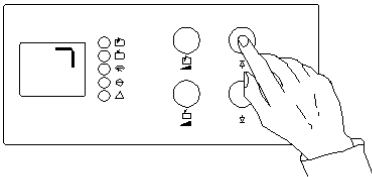

"CLOSE" direction

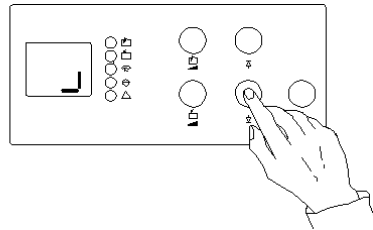

Press button "P"

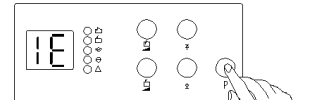

Press button "P"

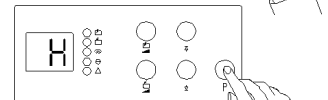

Press button "P" only with
autom. timed return

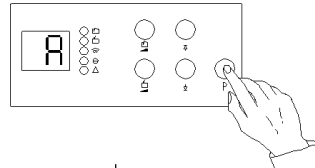

Press button "P"

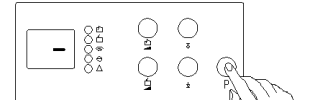

LED ☹️ lights up

Programming is completed.

9i

Setting the limit stop for the two-wing version - gate 2

Press button "P" for 2 seconds

"F" is indicator

LED ☺ lights up

LED ⊖ flashes

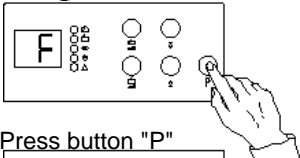

Press button "P"

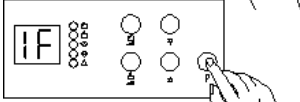

Press button "P"

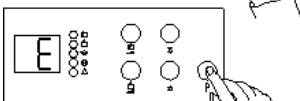

Press button "P"

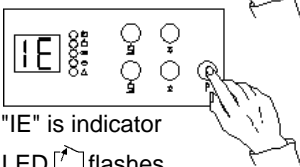

"IE" is indicator

LED ☹ flashes

Press button ∇ and keep it depressed until the gate has reached the final "CLOSE" position.

Fine adjustment can be made by briefly pressing button ∇ or button \triangle which increases or reduces the travel distance of the gate by approx. 4 mm, without the gate moving!

The final "CLOSE" position (limit stop) is stored.

Press button \triangle and keep it depressed until the gate has reached the final "OPEN" position.

Carry out fine adjustment as described above.

The final "OPEN" position (limit stop) is stored.

"OPEN" direction

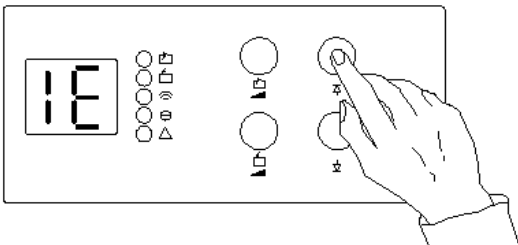

"CLOSE" direction

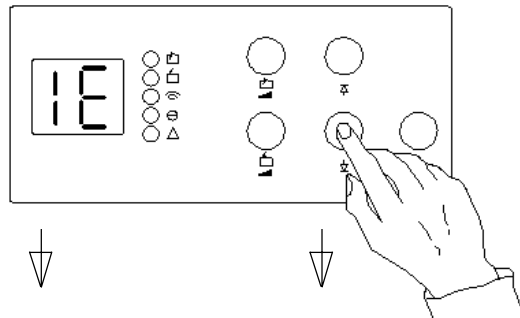

Press button "P"

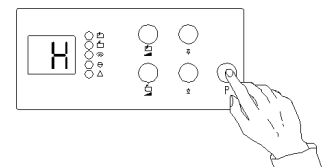

Press button "P" only with
autom. timed return

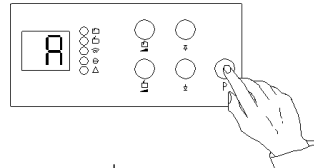

Press button "P"

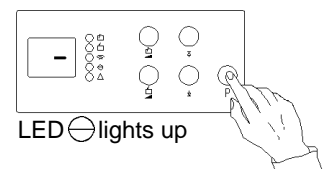

LED ⊖ lights up

Programming is completed.

9j

Setting the time-delayed start for the two-wing version

Press button "P" for 2 seconds

"F" is indicator

LED ☹️ lights up

LED ⦿ flashes

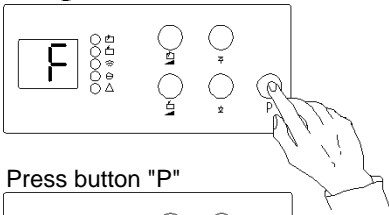

Press button "P"

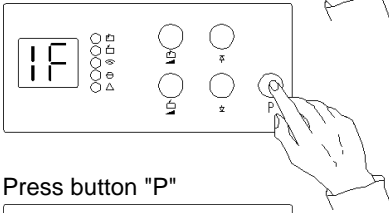

Press button "P"

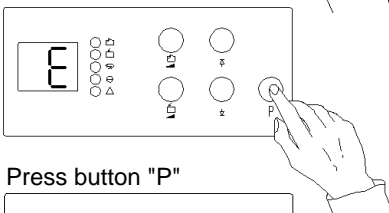

Press button "P"

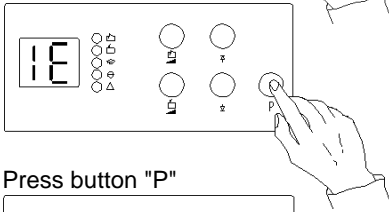

Press button "P"

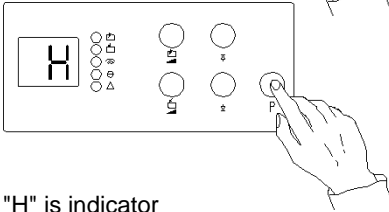

"H" is indicator

To program the time-delayed start, press button . The set value is indicator. By **repeatedly** pressing the button, the time delay can be set in stages from 0 to 19 (preset value = 2).

Indicator	Time delay
0	0.5 sek.
1	1.0 sek.
2	2.0 sek.
3	3.0 sek.
4	4.0 sek.
5	5.0 sek.
6	6.0 sek.
7	7.0 sek.
8	8.0 sek.
9	9.0 sek.
10	10.0 sek.
11	11.0 sek.
12	12.0 sek.
13	13.0 sek.
14	14.0 sek.
15	15.0 sek.
16	16.0 sek.
17	17.0 sek.
18	18.0 sek.
19	19.0 sek.

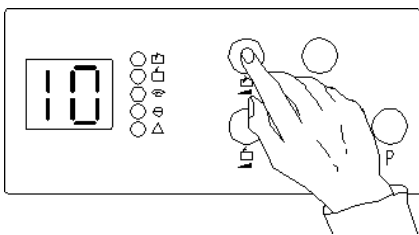

Press button "P"

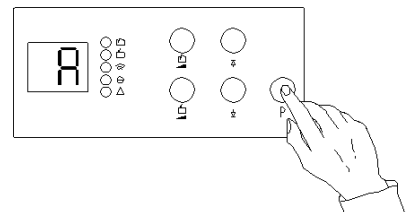

Press button "P"

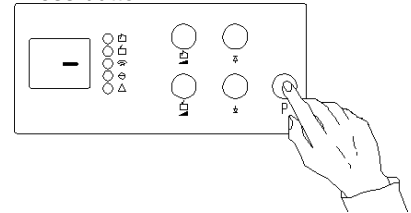

9k Programm the type of operation

Indicator for operating mode

5	-B55	Impulse/stop/impulse in opposite direction
6	-B5/B6	Impulse open/close (directional control)
7	-B5/B6	Open/close with self-hold and autom.timed return
8	-B5/B6	Open/close with self-hold and autom.timed return after driving past the site photocell

B55/B5/B6, B5/B6 with autom. timed return (pre-programmed at the factory for sequential phase control B55 - only alter if required).

Programming

Press button  and at the same time switch on the mains.

Selection via button  and storage of selected setting via button "P" (after 30 seconds storage is automatic).

Indicator 7 to 8:

Setting the "prewarning" or "gate open time" in accordance with fig. 9n.

Connection of red traffic light H20 to terminal 1 and N (X2b as per fig. 7)

9l Programming the light relay K6

Indicator for operating mode 2 to 6

1	3-minute light phase
2	Flashing pulse
3	Gate operational

Indicator for operating mode 7, 8, 9

2	Flashing light
3	Revolving beacon

(pre-set at the factory for 3-minute light phase, only alter if required).

Programming

Press button  and at the same time switch on the mains.

Select via button  and store selected setting by pressing button "P" (after 30 seconds storage is automatic).

Connect up site lighting, flashing light or beacon in accordance with the circuit diagram.

9m Indicator

Function messages		Fault messages	
Indicator	Function	Indicator	Indicator Fault
0	Stop button	8	Reference contact without function motor 1 /
2	Impulse OPEN (button/remote control)	9	Hybrid photocell (speed registration) w/out function motor 1
4	Impulse CLOSE (button/remote control)	10	Power limit motor 1
6	Driveway photocell	11	Operation time limitn
7	Programming abrupted	16	Safety device testing not o.k.
		17	Reference contact without function motor 2
		18	Hybrid photocell (speed registration) w/out function motor 2
		19	Power limit motor 2

9n Cancelling the settings

Press button "P" and at the same time switch on the mains. "c" appears in the indicator.

90

Setting the automatic timed return (only operation type 7 and 8 in accordance with fig. 9k)

Press button "P" for 2 seconds
 "F" is indicator
 LED ☺ lights up
 LED ☹ flashes

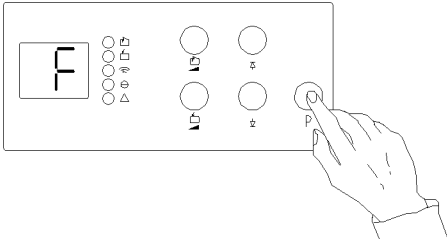

Press button "P" again until "A" appears in the indicator.

Press button "P"

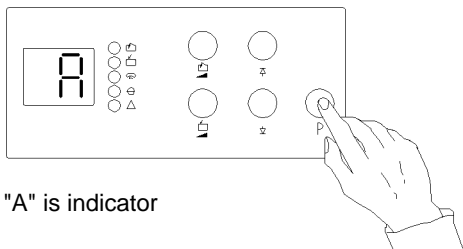

"A" is indicator

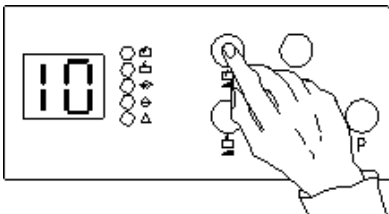

Open time

Press button or button - selected setting is indicator.

By repeatedly pressing the appropriate button, the "open time" and the "prewarning time" can be set in stages from 0 to 15. (pre-set value = 1).

Indicator	Open time	Prewarning time
0	5 sek.	2 sek.
1	10 sek.	4 sek.
2	15 sek.	6 sek.
3	20 sek.	8 sek.
4	25 sek.	10 sek.
5	30 sek.	12 sek.
6	35 sek.	14 sek.
7	40 sek.	16 sek.
8	50 sek.	18 sek.
9	60 sek.	20 sek.
10	80 sek.	22 sek.
11	100 sek.	24 sek.
12	120 sek.	26 sek.
13	150 sek.	28 sek.
14	180 sek.	30 sek.
15	255 sek.	32 sek.

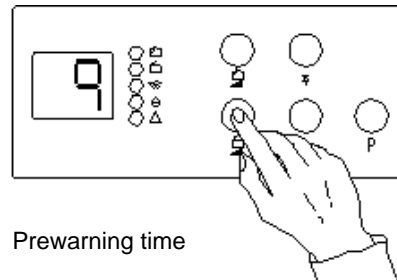

Prewarning time

Press button "P"

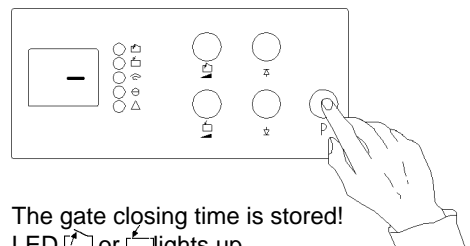

The gate closing time is stored!
 LED or lights up.

Programming is completed.

10 Disengaging the drive operator in the event of a power failure

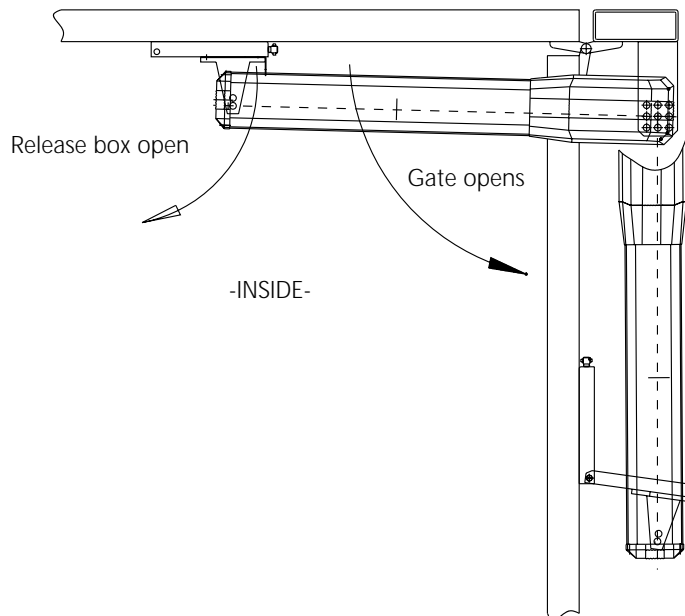
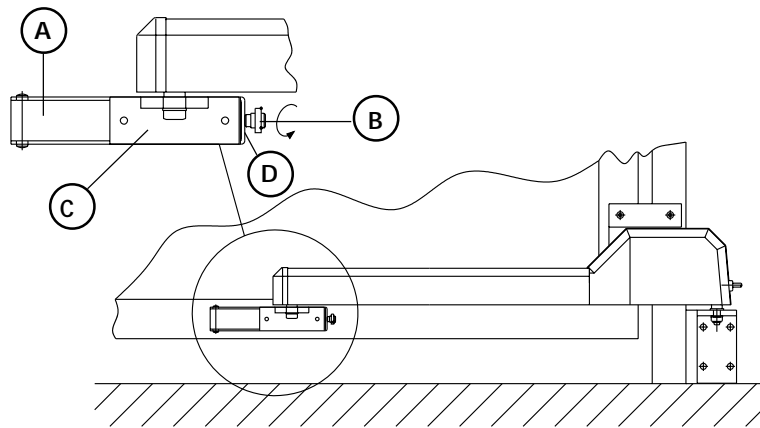

a) Release from the inside

Turn rotary latch (B) around 90°. The release box (A) opens. The gate can then be operated manually.

b) Release from the outside (not part of the supply package)

Insert the key, turn 180 degrees clockwise and withdraw the key with the inner cylinder until the release box opens. The gate can then be opened manually.

Important: Before resuming power-operation, allow the gate to latch into the release box manually and lock.

It is advisable to test the release mechanism from time to time to ensure it is in good working order.

Note: After actuating the release, the gate can be fully opened in the closed position but cannot be closed in the open position. In this instance, the drive operator must be unscrewed from the gate.

A Release box

B Rotary latch

C Location piece

D Location hole for shackle-type lock (not part of the supply package) to secure the rotary latch.

11 Fitting the electr. lock (optional accessory - to be used for gate wings wider than 2000 mm)

11a Electr. lock on single-wing hinged gate (electr. gate post lock, code no. 562 917, required)

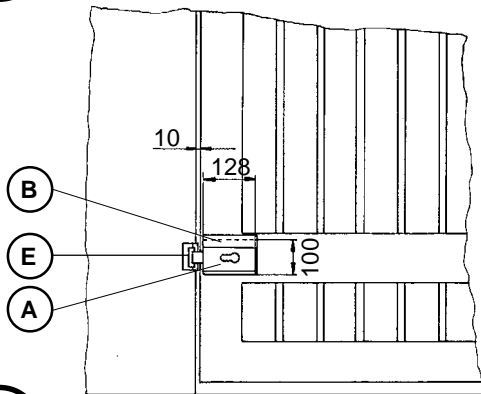

Screw mounting plate (B) to gate wing and fit electric lock (A). Secure striking plate (E) to the post. Wire the electr. lock in accordance with the circuit diagram.

11b Electr. lock on each wing of a two-wing gate system (2 x electr. ground locks, code no. 562 919 and - if not provided - stop plate with opening to accept electr. lock bolt, code no. 562 924, required).

Screw mounting plate (B) to gate wing and fit electr. lock (A). Attach stop plate (C). Wire electr. lock in accordance with the circuit diagram.

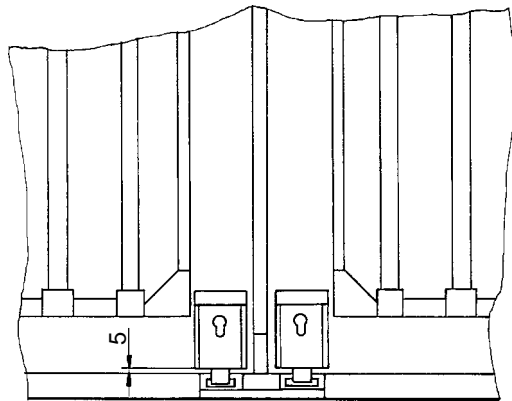

11c Electr. lock on two-wing hinged gate system with stop bars (electr. ground lock, code no. 562 919 and - if not provided - stop plate with recess to take bolt of electric lock, code no. 562 924, required).

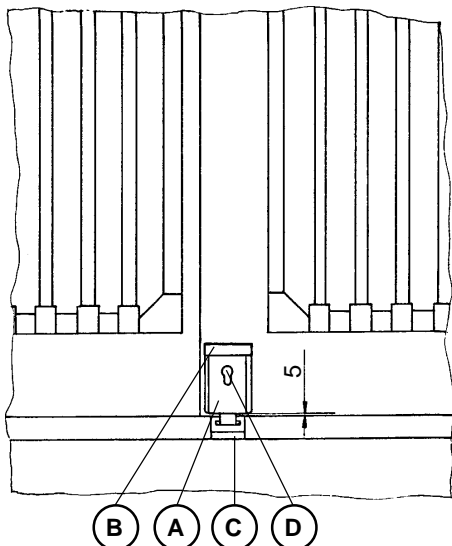

Screw mounting plate (B) to gate wing and fit electr. lock (A). Attach stop plate (C). Wire electr. lock in accordance with the circuit diagram.

- A Electr. lock
- B Mounting plate
- C Stop plate
- D Closing cylinder
- E Striking plate

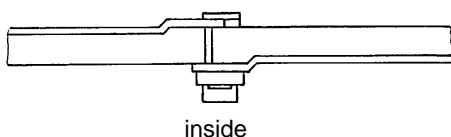

12

Test Instructions (only for the specialist!)

Trouble shooting

Fault	Cause	Remedy
No green light on operation lamp.	No voltage.	Check mains supply. Check mains fuse F1.
	Thermal protection is activated.	Allow motor to cool down.
Fault indicator flashing "red" indicator 10 or 19	Automatic cut-out set too sensitively. Door operation too sluggish. as per fig. 10c. Door blocks.	Adjust automatic cut-out to be less sensitive. Ensure door moves easily.
Indicator 9 or 18 Drive operates w/o self-hold.	Two-way photocell revs/min. is defective.	Replace two-way photocell revs/min.
No function	Defective electronics	Disconnect drive unit from the mains. Remove electronic circuit boards and have them tested.
No reaction on impulse	Connecting terminals for "impulse" button bridged, e.g. due to short-circuit or wrong terminal connection.	Isolate wired key switches or push buttons by way of trial and look for wiring fault.



EN 55011
EN 50081
EN 50082
ETS 300220

Ausgabe 09.99 HF 83 704 GB / M. 0,5 Stand 12.96